

TRUCK, COMMAND RECONNAISSANCE, 1/4-TON, 4 x 4 (Ford, Model GPW; Willys, Model MB)

NOTE: ALL DIMENSIONS SHOWN
ARE IN INCHES

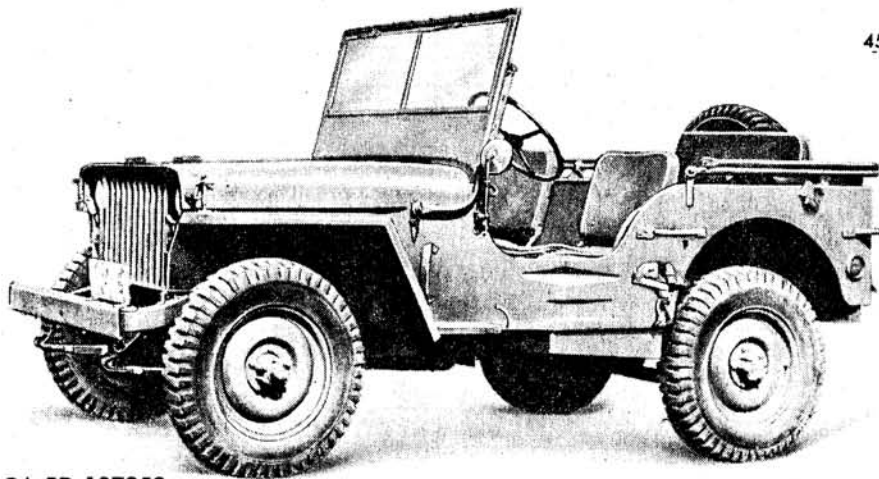

RA PD 137858

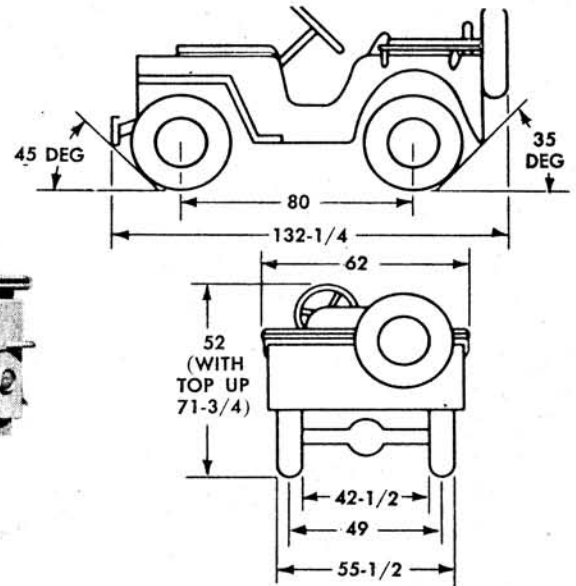

Technical Manuals: 9-803, 9-1803A, 9-1803B, 9-1825B, 9-1826A, 9-1827C, 9-1828A; Supply Catalog: SNL G-503.

Classification: Standard.

Purpose: To transport command and reconnaissance personnel and light cargo.

GENERAL DATA

Crew	2; Passengers (including) crew 5
Weight (lb)	Net 2,450
Payload.....	off highway 800; on highway 1,200
Gross.....	off highway 3,250; on highway 3,650
Live-axle gear ratio	4.88 : 1
Axle load (lb):	
Empty.....	front 1,240; rear 1,210
Loaded:	
Off highway.....	front 1,390; rear 1,860
On highway.....	front 1,465; rear 2,185
Tires	Ply 6; Size 6.00 x 16; Pressure (psi) 30
Tread, center-to-center, front.....	(in.) 49
Shipping dimensions, uncrated	(cu ft) 247; (sq ft) 57
Vehicle dimensions:	
Ground clearance.....	(in.) 8 3/4
Pintle height, loaded.....	(in.) 21
Electrical system	(volts) 6
No. of batteries.....	1
Type of ground.....	negative
Fuel octane rating	68
Capacities:	
Fuel.....	(gal) 15
Cooling system.....	(qt) 11
Crankcase, refill.....	(qt) 4
Transfer.....	(qt) 1 1/2
Transmission.....	(qt) 3/4
Axles (each).....	(qt) 1 1/4
Brakes:	
Manufacturer; Bendix.....	Type; hydraulic
Parking brake, type.....	transmission
Transmission:	
Forward speeds.....	3
Gear ratio.....	High 1:1; Low 2.665 : 1
Transfer:	
Speeds.....	2
Gear ratio.....	High 1:1; Low 1.97 : 1

PERFORMANCE

Computed grade ability in lowest gear, loaded	(percent) 58
Turning radius (ft)	right 18; left 18 1/2
Fording depth	(in.) 25
Fuel consumption, loaded	(mpg) 19
Cruising range, loaded	(mi) 285
Allowable speed, recommended	(mph) 65
Maximum recommended towed load:	
Off highway.....	gross-(lb) 1,000
On highway.....	gross-(lb) 2,000

ENGINE

Manufacturer: Willys.....	Model 442
Type	L-head, 4-cycle; No. of cylinders (in line) 4
Displacement	(cu in.) 134.2
Bore	(in.) 3 1/8
Stroke	(in.) 4 3/8
Compression ratio	6.48 : 1
Governed speed	not governed
Brake horsepower (max w/std accessories)	54 at (rpm) 4,000
Torque (max)	105 lb-ft at (rpm) 2,000

ADDITIONAL DATA

Live axles, type	hypoid, full-floating
Transmission, type	synchromesh